

**Nikon**

Biological Microscope



**Biological Microscope**

**YS100**

# A microscope designed to meet your needs and exceed your expectations



Thanks to Nikon's overall optical design, coupled with industry-acclaimed chromatic aberration-free optics, the YS100 produces images that are needle-sharp and of high contrast, including the periphery of the viewing field. In addition, the prism-type eyepiece tube and high-output 6V 20W halogen light source provide bright images. Operation? It's as simple as can be! All controls, including focusing and mechanical stage movement, are conveniently located for simple operation. And last but not least, the YS100 is rigidly built for many years of reliable use. So, whatever your purpose—medical, scientific, or educational—the YS100 is an ideal choice.

## Anti-mold design

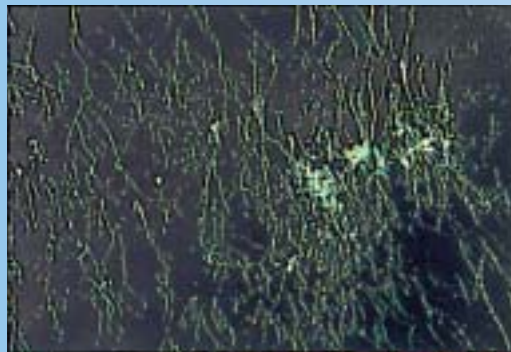

Mold growing on a lens surface

In regions where heat and humidity are high, mold is a constant threat. If you do not store your microscope in a cool, dry place, mold can grow on the lens surfaces, obscuring the images seen through the optical system. With the YS100, there is no need to worry. Thanks to Nikon's anti-mold paint and tablets, this is no longer a problem. In laboratory tests, mold did not form for up to five years, even at a 30°C temperature and 80% humidity.

### Mold-prone seasons in major regions of the world

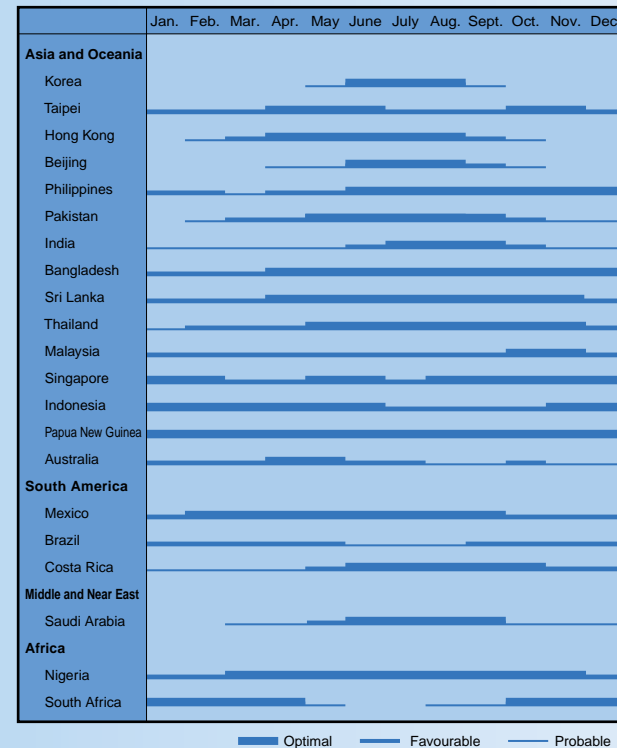

Note: Data is based on average monthly temperature and humidity and refers to the type of mold that grows on optical surfaces.

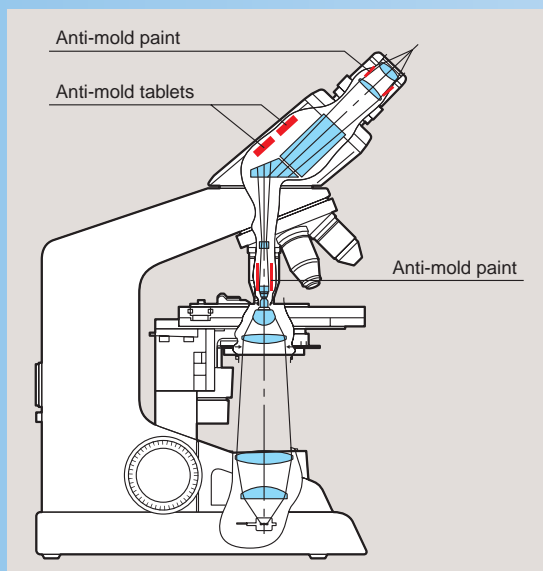

# Nikon's legendary optics, rigid design, plus easy operation

## Prism-type eyepiece tube with advanced diopter compensation feature

The YS100 comes standard with a prism-type binocular eyepiece tube and features a compensation function that corrects the diopter in both the right and left eyepiece lenses. This design not only produces brighter images than those obtained with a mirror-type eyepiece tube, but also allows the user to adjust for parfocality. By using the eyepiece diopter adjustments to correct the optical tube length, the objective parfocality is maintained when adjusting the interpupillary distance. This eliminates the need for refocusing when switching to different objective magnifications and results in clear images with minimum spherical aberrations. A monocular type eyepiece tube is also available as a lower cost option. The 10X eyepiece lens (F.O.V. 18) is standard, while a 15X ocular is available as an option. The eyepiece lens cup is made of elastic material providing soft touches for comfortable viewing.



## Easy-to-rotate nosepiece

The high-quality quadruple revolving nosepiece has an internal click-stop mechanism. This design makes rotation smooth, while increasing its durability. Also, a knurled grip around the base of the nosepiece makes the nosepiece easy to rotate and eliminates the need to touch the objectives.



## Condenser is also simple to use

The condenser comes with an aperture diaphragm with position guide markings for the 4X, 10X, 40X, 60X and 100X objectives to make operations quick and easy, ensuring perfect specimen images.



## Double-plate mechanical stage

The permanently-mounted stage has a built-in double-plate mechanism with an XY travel control. Because this mechanism is built-in and not attached, the X-axis guide rail does not protrude above the height of the stage surface. This design provides ample space on the stage to facilitate easy specimen handling, while making stage motion in the X direction smoother and more precise. The stage has a smooth surface, allowing slide glasses to move freely over it.

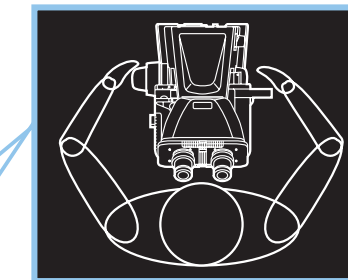

## Coaxial coarse/fine focus knob

The coaxial coarse/fine focus knob is comfortably located at desk-height level. The focus knob and the stage handle are situated at an optimum position, allowing for a natural operator posture without twisting the shoulders, a Nikon-exclusive feature.



## 6V-20W halogen light source

The powerful 6V-20W Halogen light source is adjustable (1V to 6V) for convenient illumination control. Coupled with the prism-type eyepiece tube, this design contributes to bright images even for dark stained specimens. Moreover, lamp replacement is easy and trouble-free, unlike other microscopes of this class, which access the bulb from the bottom of the base. The YS100 allows quick bulb replacement without having to turn the microscope upside down.

## Convenient Accessories

### Tamper-proof design

Use of the microscope by multiple users always involves the possibility of its optical and mechanical components getting lost. To prevent this, the YS100 is designed so that its eyepieces, objectives, and mechanical stage can be locked, using tools available from Nikon.

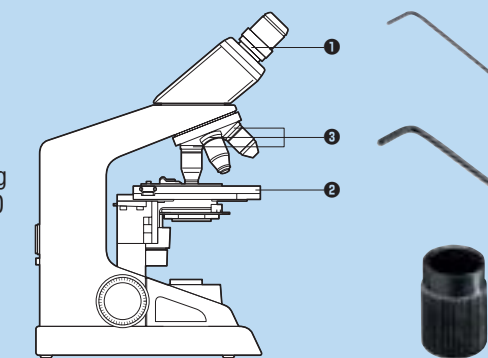

### 1 Eyepiece locking tool (Hexagonal wrench)

Allows the eyepieces to be fixed securely.

### 2 Mechanical stage locking tool (Hexagonal wrench)

For securing the mechanical stage in place.

### 3 Objective locking tool (Option)

Used to tighten the objectives in their nosepiece to prevent removal.

## Convenient Accessories

### Phase-contrast attachment

Use of this attachment enables phase contrast and brightfield observations easily and at an economical price.

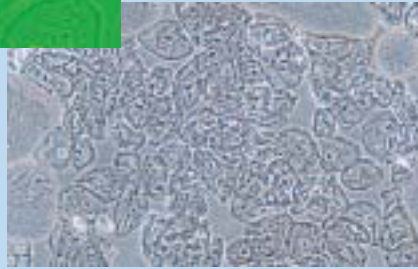
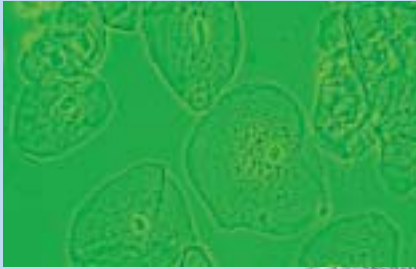

Phase-contrast accessories

### Darkfield ring unit

Darkfield observation—at magnifications from 10X to 40X—is possible, simply by attaching this inexpensive unit to the condenser.

### Carrying case

Handy when the microscope is in transit or for storing the unit when not in use.

### Photomicrography

Nikon's FX-III series H-III photomicrographic system can be mounted to this microscope by using an optional trinocular "F" eyepiece tube. With a built-in control box and a reduced number of controls, the H-III is simpler to operate than ever before. Auto exposure, 1% spot, and 35% integrated average metering functions are provided.

### Object marker

The object marker places a 1.8 mm diameter black circle (non-permanent ink) on the cover glass to indicate a point of interest within the specimen. The 1.8 mm diameter ink mark indicates the field of view using the 10X objective.



### Cord hanger

A cord hanger is available as an option to make storage easier. The power cord can be conveniently wound around on the back of the microscope stand when not in use.

## Specifications

<b>Magnification range</b>	40X–1500X
<b>Nosepiece</b>	Quadruple click-stop, revolving mechanism with multiple ball bearings; Elastic nosepiece grip-ring
<b>Eyepiece tube (Anti-mold)</b>	Binocular; 45° inclined; built-in prism type; Diopter adjustment for both eyepiece lenses; Interpupillary distance adjustment: 52-74 mm Monocular; 45° inclined
<b>Eyepiece lens (Anti-mold)</b>	CFWE 10X F.O.V. 18mm with rubber eye guard CFWE 15X F.O.V. 12mm with rubber eye guard
<b>Coarse and fine focusing</b>	Coaxial coarse/fine focusing with cross roller guide incorporated; 22mm coarse/fine focusing range; Coarse motion is 37.7mm per rotation. Fine motion is 0.2mm per rotation with 2µm scale increments; Coarse motion torque adjustable; Symmetric positioning of fine control and stage handle
<b>Rectangular mechanical stage</b>	Stage size 155 (W) x 134 (D) mm; Double-plate system stage; Removable slide holder; Travel area 76 (X) x 40 (Y) mm with a right-hand stage handle; Vernier reading to 0.1mm provided
<b>Substage</b>	Adjustable vertical condenser movement range 10mm
<b>Condenser</b>	Abbe type N.A. 1.25 with objective marking position; Accepts 33mm diameter filters; Includes standard blue filter
<b>Objective lenses (Anti-mold)</b>	Achromat 4X, N.A. 0.10, W.D. 25mm Achromat 10X, N.A. 0.25, W.D. 5.6mm Achromat 40X, N.A. 0.65, W.D. 0.6mm, spring loaded Achromat 100X oil, N.A. 1.25, W.D. 0.14mm, spring loaded
<b>Illumination</b>	Halogen 6V-20W; Maximum voltage 6V; Lamp changeable by removing the field lens unit
<b>Optional accessories</b>	Phase contrast attachment (10X, 40X, 100X oil), Achromat 60X objective, cord hanger, etc.

## Dimensional Diagram

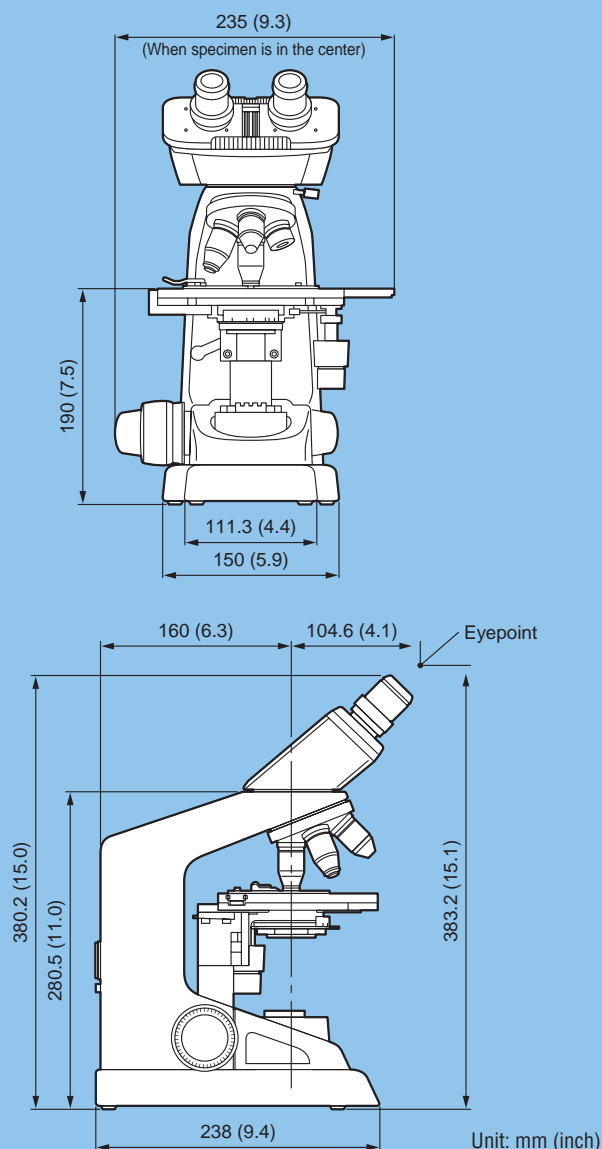

Specifications and equipment are subject to change without any notice or obligation on the part of the manufacturer. December 2001. ©2000/01 NIKON CORPORATION

	<b>WARNING</b>	TO ENSURE CORRECT USAGE, READ THE CORRESPONDING MANUALS CAREFULLY BEFORE USING YOUR EQUIPMENT.
--	----------------	--



### NIKON INSTECH CO., LTD.

Parale Mitsui Bldg., 8, Higashida-cho, Kawasaki-ku, Kawasaki, Kanagawa 210-0005, Japan  
phone: +81-44-223-2167 fax: +81-44-223-2182  
<http://www.ave.nikon.co.jp/inst/>

### NIKON SINGAPORE PTE LTD

SINGAPORE phone: +65-5593618 fax: +65-5593668

### NIKON MALAYSIA SDN. BHD.

MALAYSIA phone: +60-3-78763887 fax: +60-3-78763387

### NIKON EUROPE B.V.

P.O. Box 222, 1170 AE Badhoevedorp, The Netherlands  
phone: +31-20-44-96-222 fax: +31-20-44-96-298

### NIKON FRANCE S.A.

FRANCE phone: +33-1-45-16-45-16 fax: +33-1-45-16-00-33

### NIKON GmbH

GERMANY phone: +49-211-9414-0 fax: +49-211-9414-322

### NIKON INSTRUMENTS S.p.A.

ITALY phone: +39-55-3009601 fax: +39-55-300993

### NIKON AG

SWITZERLAND phone: +41-1-913-62 00 fax: +41-1-910-37 44

### NIKON UK LTD.

UNITED KINGDOM phone: +44-20-8541-4440 fax: +44-20-8541-4584

### NIKON INSTRUMENTS INC.

1300 Walt Whitman Road, Melville, N.Y. 11747-3064, U.S.A.  
phone: +1-631-547-8500; +1-800-52-NIKON (within the U.S.A. only) fax: +1-631-547-0306  
<http://www.nikonusa.com/>

### NIKON CANADA INC.

CANADA phone: +1-905-625-9910 fax: +1-905-625-0103



**EINST**  
EINST Technology Pte Ltd  
Tel: +65 6748 5828 Fax: +65 6748 9113  
Email: [sales@einstinc.com](mailto:sales@einstinc.com) URL: [www.einstinc.com](http://www.einstinc.com)

 **NIKON CORPORATION** <http://www.nikon.com/>

Printed in Japan (0112-10)T

Code No. 2CE-MTNH-6

This brochure is printed on recycled paper made from 40% used material.

**E**